

ASSP

1 CHANNEL 8-BIT VIDEO A/D CONVERTER

MB40558

■ DESCRIPTION

The Fujitsu MB40558 is a low power ultra-high speed video A/D converter fabricated with Fujitsu Advanced Bipolar Technology. The MB40558 also adopts the fully-parallel comparison technique (flash method) for high speed conversion and can convert wide band analog signal such as video signal to digital signal at sampling rate of DC through 40 Mega-samples/sec. Because of such high speed operation, the MB40558 is suitable for digital video applications such as the digital TV, video processing with computer, or ladder signal processing.

■ FEATURES

- Resolution: 8 bits
- Linearity Error: $\pm 0.15\%$
- Maximum Conversion Rate: 40 MSPS (min.)
- Digital I/O Level: TTL Compatible
- Analog Input Voltage: 3.0V to 5.0V(2Vp-p)
- Single Power Supply: 5.0V
- Power dissipation: 350 mW (typ.)
- Further Function: On Chip Reference Voltage Generator
- Package: Standard 20-pin Plastic DIP Package: Suffix: -P
Standard 20-pin Plastic Flat Package: Suffix: -PF

■ PACKAGES

Plastic DIP, 20 pin

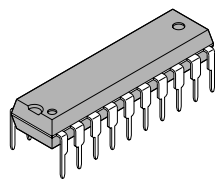

(DIP-20P-M01)

Plastic FPT, 20 pin

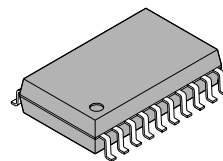

(FPT-20P-M02)

MB40558

■ PIN ASSIGNMENT

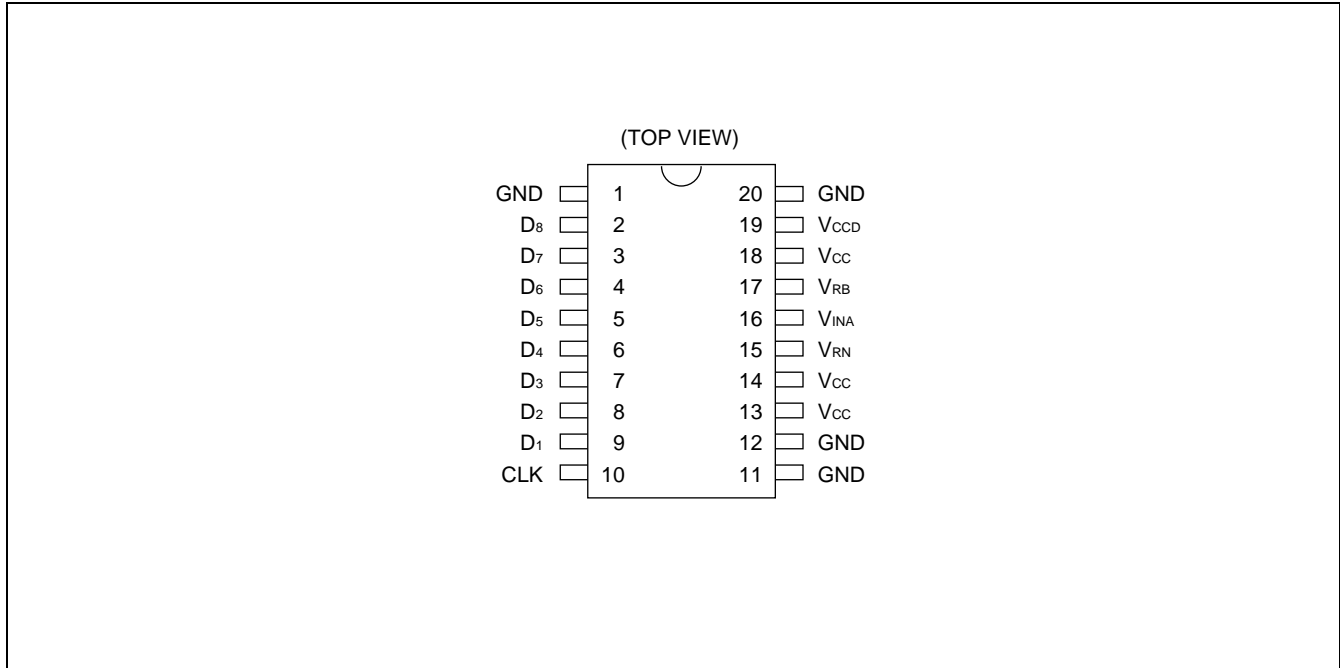

■ BLOCK DIAGRAM

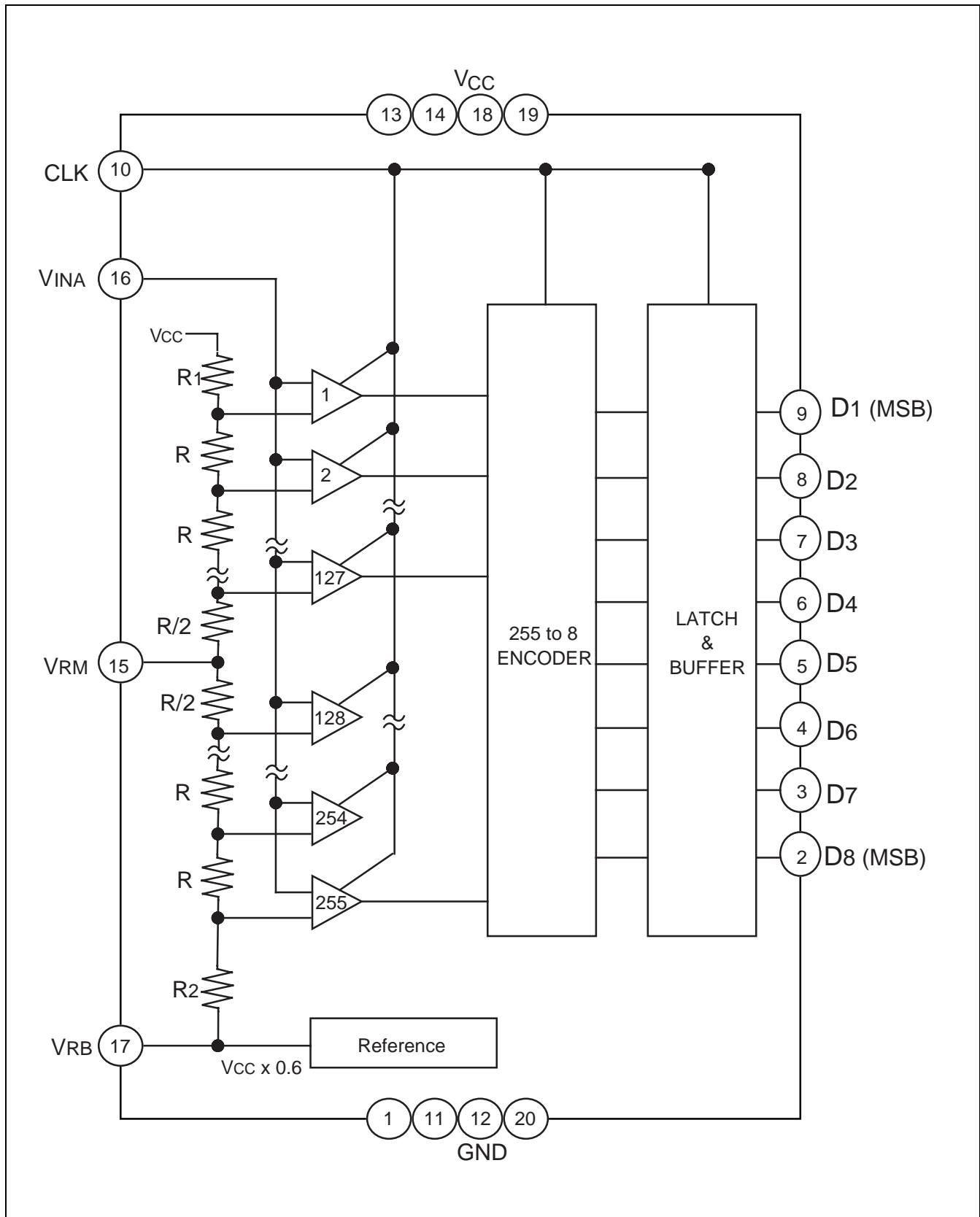

MB40558

■ ABSOLUTE MAXIMUM RATINGS

Parameter	Symbol	Value	Unit
Power supply voltage	V _{CC}	-0.5 to +7.0	V
Digital input voltage	V _{IND}	-0.5 to +7.0	V
Analog input voltage	V _{INA}	-0.5 to V _{CC} +0.5	V
Storage temperature	T _{stg}	-55 to +150	°C

Note: Permanent device damage may occur if the above **Absolute Maximum Ratings** are exceeded. Functional operation should be restricted to the conditions as detailed in the operational sections of this data sheet. Exposure to absolute maximum rating conditions for extended periods may affect device reliability.

■ RECOMMENDED OPERATING CONDITIONS

Parameter	Symbol	Value			Unit
		Min.	Typ.	Max.	
Power supply voltage	V _{CC}	4.75	5.00	5.25	V
Analog input voltage	V _{INA}	V _{RB}	—	V _{CC}	V
Digital high-level output current	I _{OH}	-400	—	—	μA
Digital low-level output current	I _{OL}	—	—	1.6	mA
Clock pulse width at high-level	t _{w+}	11.5	—	—	ns
Clock pulse width at low-level	t _{w-}	11.5	—	—	ns
Operating temperature	T _a	-20	—	70	°C

■ ELECTRICAL CHARACTERISTICS

ANALOG DC CHARACTERISTICS

(V_{CC} = 5V ±5%, GND = 0V, T_a = -20 to +70°C)

Parameter	Symbol	Value			Unit
		Min.	Typ.	Max.	
Resolution	—	—	8	—	bits
Linearity error	LE	—	±0.15	±0.3	%
Differential linearity error	DLE	—	±0.12	—	%
Equivalent resistance for analog input	R _{INA}	0.18	2.8	—	MΩ
Analog input capacitance	C _{INA}	—	40	—	pF
Analog high-level input current	I _{IHA}	—	—	195	μA
Analog low-level input current	I _{ILA}	—	—	185	μA
Reference voltage	V _{RB}	0.6 × V _{CC} - 0.1	0.6 × V _{CC}	0.6 × V _{CC} + 0.1	V
Power supply current	I _{CC}	—	70*	130	mA

* : V_{CC} = 5.0V, T_a = +25°C

DIGITAL DC CHARACTERISTICS

(V_{CC} = 5 V ±5%, GND = 0V, T_a = -20 to +70°C)

Parameter	Symbol	Value			Unit
		Min.	Typ.	Max.	
High-level output voltage	V _{OHD}	2.7	—	—	V
Low-level output voltage	V _{OLD}	—	—	0.4	V
High-level input voltage	V _{IHD}	2.0	—	—	V
Low-level input voltage	V _{ILD}	—	—	0.8	V
High-level input current	I _{IHD}	—	—	20	μA
Low-level input current	I _{ILD}	-100	—	—	μA

SWITCHING CHARACTERISTICS

(V_{CC} = 5 V ±5%, GND = 0V, T_a = -20 to +70°C)

Parameter	Symbol	Value			Unit
		Min.	Typ.	Max.	
Maximum conversion rate	fs	40	—	—	MSPS
Digital output delay time	tpd	6	11	21	ns

MB40558

■ PACKAGE DIMENSIONS

Plastic DIP, 20 pin
(DIP-20P-M01)

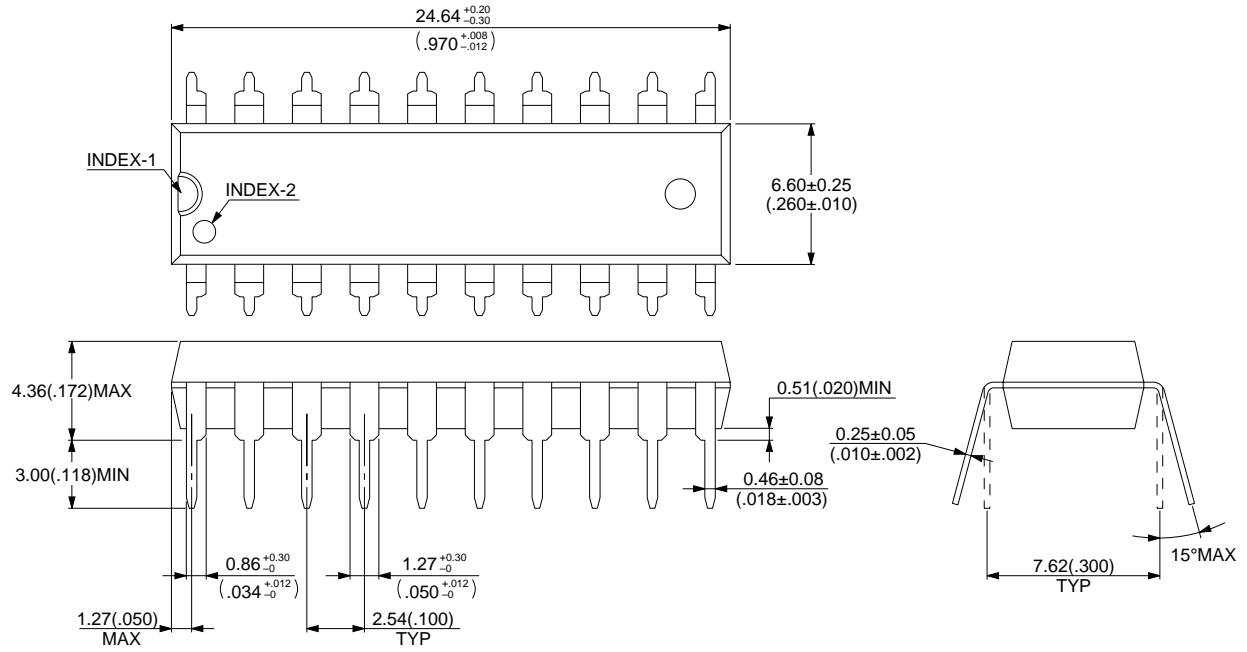

© 1994 FUJITSU LIMITED D20005S-3C-3

Dimensions in mm(inches)

Plastic FPT, 20 pin
(FPT-20P-M02)

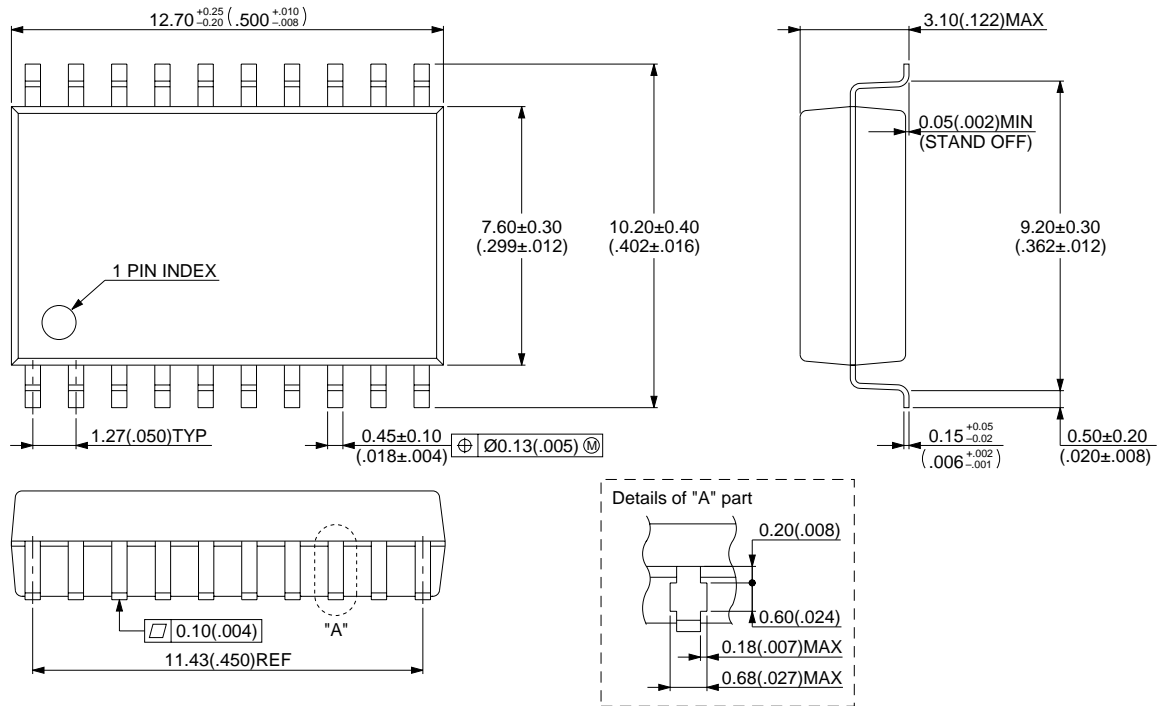

© 1994 FUJITSU LIMITED F20006S-4C-4

Dimensions in mm(inch)

FUJITSU LIMITED

For further information please contact:

Japan

FUJITSU LIMITED
Corporate Global Business Support Division
Electronic Devices
KAWASAKI PLANT, 4-1-1, Kamikodanaka
Nakahara-ku, Kawasaki-shi
Kanagawa 211-88, Japan
Tel: (044) 754-3753
Fax: (044) 754-3329

North and South America

FUJITSU MICROELECTRONICS, INC.
Semiconductor Division
3545 North First Street
San Jose, CA 95134-1804, U.S.A.
Tel: (408) 922-9000
Fax: (408) 432-9044/9045

Europe

FUJITSU MIKROELEKTRONIK GmbH
Am Siebenstein 6-10
63303 Dreieich-Buchsschlag
Germany
Tel: (06103) 690-0
Fax: (06103) 690-122

Asia Pacific

FUJITSU MICROELECTRONICS ASIA PTE. LIMITED
No. 51 Bras Basah Road,
Plaza By The Park,
#06-04 to #06-07
Singapore 189554
Tel: 336-1600
Fax: 336-1609

All Rights Reserved.

Circuit diagrams utilizing Fujitsu products are included as a means of illustrating typical semiconductor applications. Complete information sufficient for construction purposes is not necessarily given.

The information contained in this document has been carefully checked and is believed to be reliable. However, Fujitsu assumes no responsibility for inaccuracies.

The information contained in this document does not convey any license under the copyrights, patent rights or trademarks claimed and owned by Fujitsu.

Fujitsu reserves the right to change products or specifications without notice.

No part of this publication may be copied or reproduced in any form or by any means, or transferred to any third party without prior written consent of Fujitsu.

The information contained in this document are not intended for use with equipments which require extremely high reliability such as aerospace equipments, undersea repeaters, nuclear control systems or medical equipments for life support.